

Assembly & Maintenance Guide



Amsterdam
3-Speed



LEKKER®



Contact

Australia

Phone

03 4828 3202 – Melbourne

03 4828 3202 – Sydney

Address

23 Provost Street,
North Melbourne,
3051, VIC, Australia
415 Bourke Street, Surry Hills,
2010, NSW, Australia

Email

info.au@lekkerbikes.com

sydneystore@lekkerbikes.com

Europe & USA

Phone

+31-681878491

Address

Tweede Kostverlorenkade 68
Amsterdam, The Netherlands

Email

info.eu@lekkerbikes.com

info.us@lekkerbikes.com

lekkerbikes.com



Warning

For safety purposes it is recommended that you have this bicycle assembled by a skilled bicycle mechanic.

Enjoy your Amsterdam 3-Speed

Dear LEKKER Customer, First and foremost – congratulations on your brand new bicycle! We can't wait for you to experience the thrill and joy of riding your LEKKER bike, the Amsterdam way. But before you do, we want to help you make sure your bike is in tip-top condition, as well as provide you with some tips and tricks to keep it that way.

This manual will outline all the tools and knowledge needed to put the finishing touches on your bike, as well as how to use it and useful guidance on maintenance and care. Feast your eyes on what's to come – we guarantee it'll be worthwhile, even if you're an experienced rider.

The first few chapters are particularly important, for both your enjoyment and safety, as we walk you through key steps in ensuring your bike is safe to ride.

Please also note that as your brand new Amsterdam 3-Speed is hot off the press, the images in this manual are not reflective of the bike that's in front of you. The images used are from one of our older bike models. And without them, we thought your manual wouldn't look quite so beautiful.



Note: We have to stress that this manual won't teach you all the skills of a bicycle mechanic. Even a manual the size of every Harry Potter book combined couldn't detail every possible combination, tricks and available components. For this reason, our manual is only applicable to your new LEKKER bicycle and its assembly, alongside any important notes, warnings and maintenance guides.



Index

p08	<u>01.</u> Getting started
p12	<u>02</u> Fitting the front wheel and fender
p14	<u>03</u> Aligning the brakes
p16	<u>04</u> Aligning the gears
p18	<u>05</u> Fitting the saddle and handlebars
p22	<u>06</u> Fitting the pedals
p24	<u>07</u> Finishing touches
p26	<u>08</u> Safety and warranty

01. Getting Started

We've created this manual to help you put the finishing touches on your LEKKER bike. Run through these quick steps and you'll be exploring and adventuring in no time.

So, without further ado, unbox your LEKKER bike and feast your eyes on your newest sidekick. Once you've removed the packaging, make sure you have your trusty toolkit to hand, as shown in the illustration on the next page.

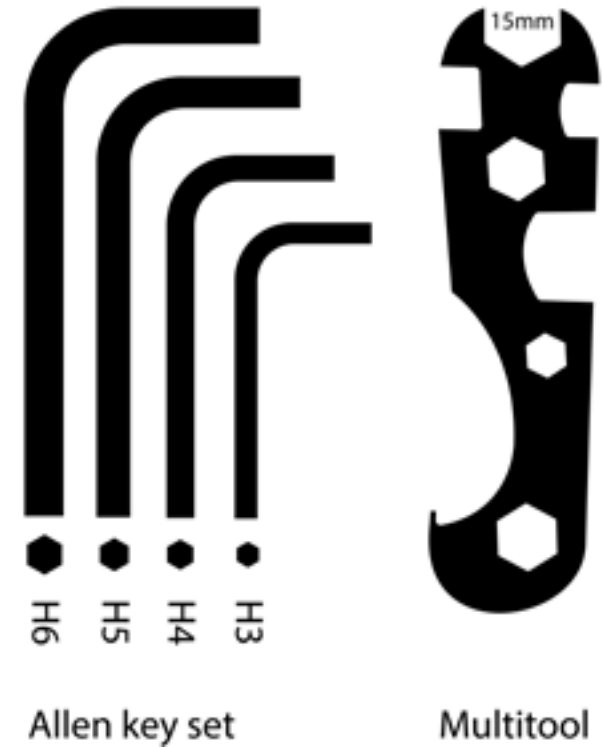



02. Fitting the front wheel and fender

Step 1: Attach the front fender

Referring to step 1 in the illustration, loosen the nut and bolt (using the 2x 5mm allen keys) that runs through the front fork and attach the fender, making sure there's enough space between the tyre and the fender.

Step 2: Attaching the front stay to the front fork

Referring to step 2 in the illustration, using the clips provided, attach the front fender stay to the front fork, using the 3 or 4mm allen key bolt

Step 3: Putting the wheel in place

Referring to step 3 in the illustration, put the wheel in place and tighten the wheel nut using the 15mm spanner

Now, on to the brakes.

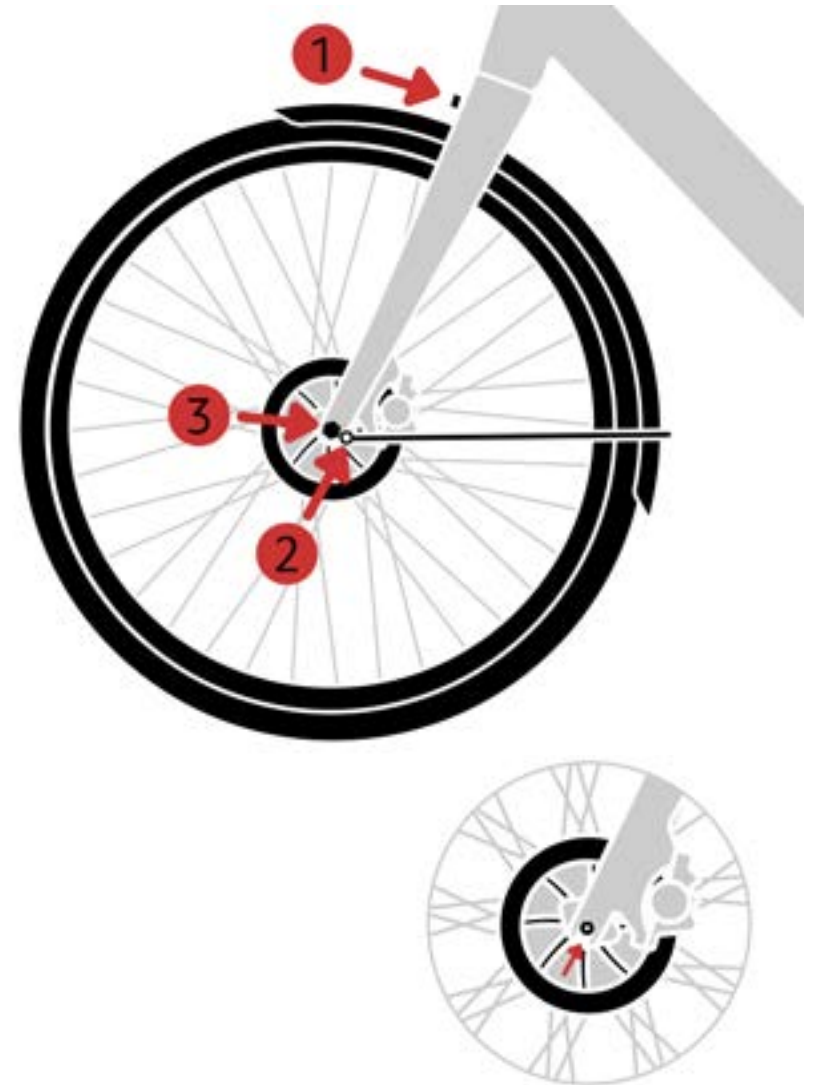

03. Aligning the brakes

Lift the wheel off the ground and give it a spin. It should spin freely and without any noise. If you hear a metallic rubbing sound, then the brakes will need adjusting.

To do this, you'll need to use the 5mm allen key. With the bike upside down, adjust the caliper. You will need to slightly loosen the two 5mm allen key bolts (found on the top of the caliper), so that you can gently move the caliper horizontally, allowing the disc rotor to move freely between the brake pads.

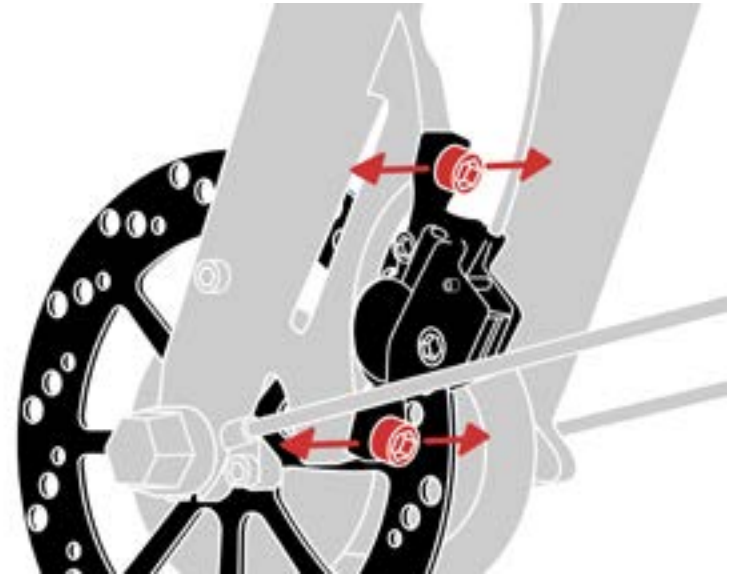

04. Aligning the gears

Step 1: Checking alignment

Begin by engaging the fourth gear on your shifting system. With the fourth gear engaged, the yellow lines should be aligned next to each other at your rear wheel axle.



Step 2: Adjusting alignment

Located on your handlebar shifter, turn the Gear Barrel Adjustor clockwise or anti-clockwise to bring the yellow lines into alignment.

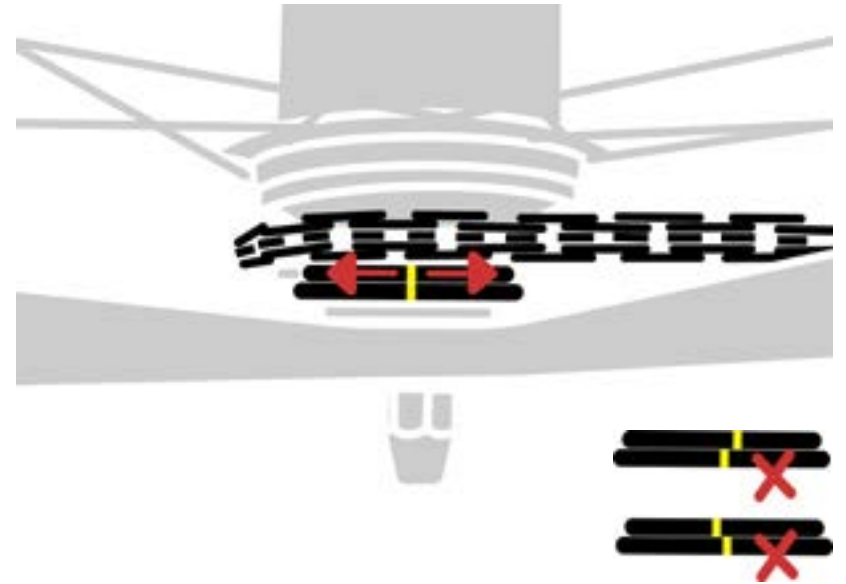

05. Fitting the saddle and handlebars

Saddle.

Using the 5mm allen key, loosen the seatpost clamp bolt and insert the seatpost. Make sure it's at the correct height. When sitting on the saddle, your knee should be at a slight bend when the pedal is at its lowest position. Then, tighten the bolt.

Tip: Using a 5mm allen key you can also adjust the angle of the seatpost and the front-to-back position of it. However, this should be correctly set already.

Handlebars.

Step 1: Now using a 4mm allen key, attach the handlebars to the handlebar stem, making sure the 4 bolts are centered and tightened properly.

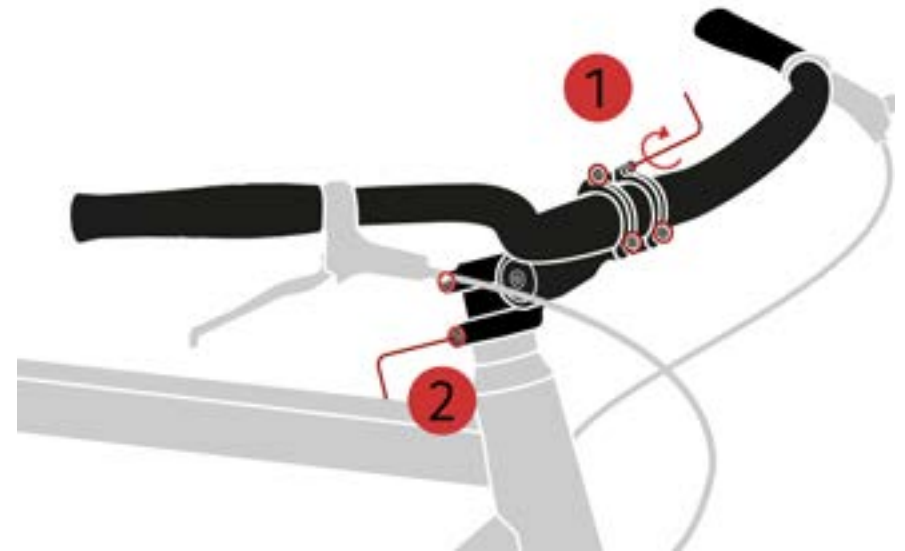

Step 2: Next, align the handlebars so that they are straight and perpendicular to the frame. Then, tighten the handlebar stem to the front fork, using the 4mm allen key.

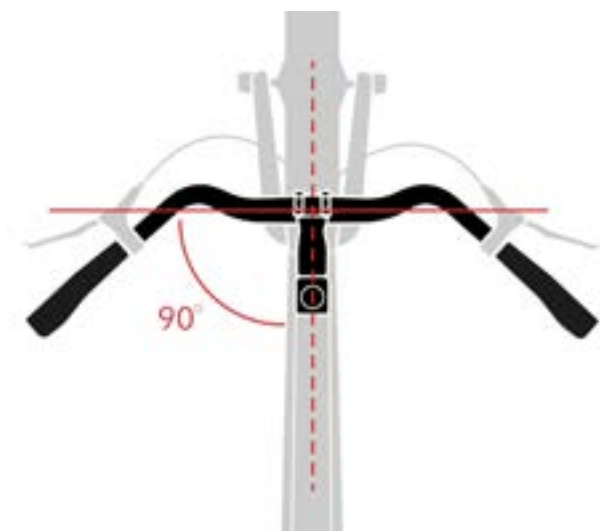

Tip: Should you wish to adjust the angles of your grips, brakes and shifter, you can do so with a simple turn of allen key 3 or 4. However, this should be correctly set already.



06. Fitting the pedals

To assemble the pedals, you will need a 15mm open-ended spanner. Insert the pedal into the crank and ensure the pedals are properly tightened.

LEFT pedal: this is the pedal that has indented horizontal lines on the small part between the pedal and thread.

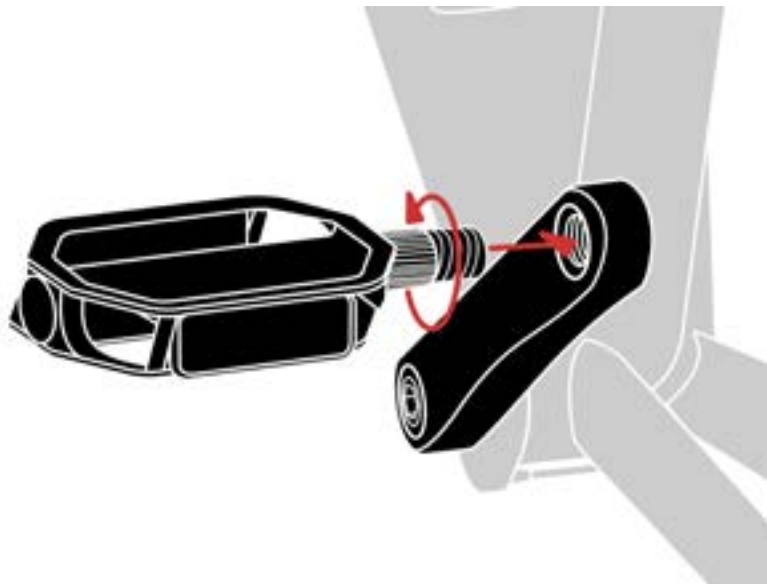

RIGHT pedal: This pedal has no indented lines and is smooth in between the pedal and thread

ATTENTION: please make sure you check the thread direction before inserting the pedals. Fitting the pedal to the wrong side can damage the crank arm and is not covered under warranty.

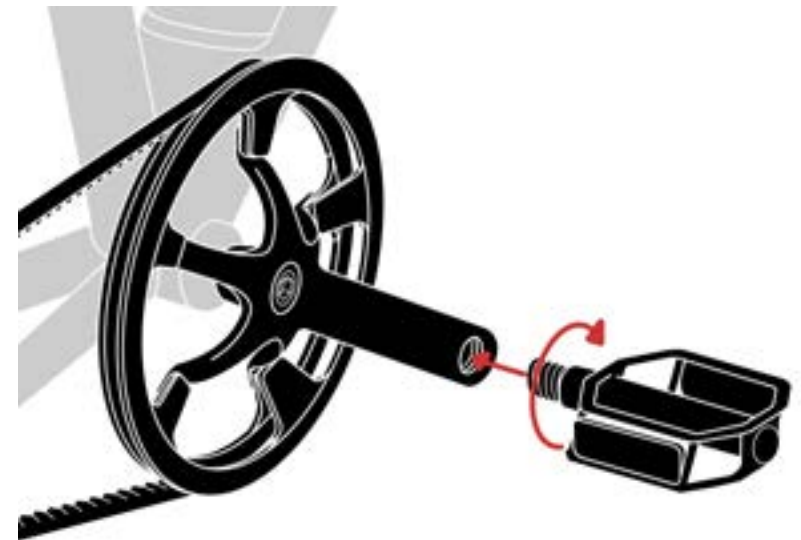

07. Finishing Touches

Install the bell on your handlebars, in your preferred position. Generally, this is on the left hand side, next to the brake lever.

Pump the tyres to 55-65 PSI

If you've ordered any accessories such as racks, locks or lights, don't forget to fit these too. They each come with their own instructions and also have their own mounting points.

Now, you're good to go. Enjoy your ride, the Amsterdam way!

08. Safety and warranty

We offer a 2-year warranty on our LEKKER frames. Additionally, we supply you with 2 years warranty on the components of our different models starting on the day of purchase. This warranty is only for replaceable components. Unfortunately, our warranty is not transferable (including when sold to another consumer) and can only be used by the original buyer of a LEKKER product. If you want to use the warranty, please ensure you have your receipt and go to the original shop in which you made your purchase.

There are cases when our warranty isn't valid. Our warranty doesn't cover wear and tear, incorrect assembly or maintenance. There's no warranty in the case of; damage caused by accidents, improper use or negligence. Our warranty is also void if changes are made to the original design of the LEKKER bike.

Please note: your frame number is located on the bottom of the bike frame, near the bottom bracket. This might be needed for insurance purposes.

**Assembly &
Maintenance Guide**

**Amsterdam
3-Speed**

lekerbikes.com

